

The so-called Simple Electric Circuit

Introduction of surface charges and transition processes for a better understanding

Hermann Härtel
University Kiel
haertel@astrophysik.uni-kiel.de

1. Basic information about electric circuits

1.1. Basic terms, definitions and processes

1.1.1. Basic elements of physical bodies

Every material object shows a grainy structure, where the basic elements of this structure - the atoms or molecules - consist of charge carriers of opposite polarity - the protons inside of the core and the electrons at the outer shells.

The existence of charge with opposite polarity cannot be further explained but has to be accepted as given by nature. The same holds for the fact that charge of equal polarity repel while charge of opposite polarity attract each other.

Protons and electrons carry the same elementary charge with opposite polarity. The elementary charge - as the name indicates - is the smallest amount of free charge that exists in nature. An equal amount of protons and electrons are seen from outside as neutral.

For historical reasons the charge of electrons is called negative, the charge of the protons as positive.

1.1.2. Definition of the unit of charge

Every macroscopic amount of charge is always an integer multiple of the elementary charge.

The unit of charge has been defined - again for historical reasons - as consisting of $6,2 \cdot 10^{18}$ elementary charges. The unit is called 1 Coulomb, in honour of the French physicist Charles Augustin de Coulomb (1736-1806).

1.1.3. Properties of conductors and isolators

Metals as good conductors and isolators as bad conductors differ in respect to the mobility of negative charge carries, the electrons. In both types the positive charge carries are fixed within the cores of the atoms, and the same holds for the electrons in isolators. However, in metals one or two electrons per atom become rather mobile within the lattice structure.

A basic law has to be mentioned here: the conservation of charge. Charge cannot be created or annihilated, at least not under normal conditions within electric devices. Within a neutral electrical device the sum of all charge carriers remains constant. It follows that within an electric device electrons can only be displaced. If electrons pile up at some place it is certain that positive charge carries will pile at some other place which has been neutral before. Repelling forces will show up between charge carriers with equal polarity and attracting forces between charge carriers of opposite polarity - the so-called Coulomb forces. These Coulomb forces are counteracting the original separation and prevent any further displacement of

electrons. Such forces show up in metals as good conductors as well as in isolators as bad conductors.

1.1.4. Importance of closed circuits

The big advantage of metal as good conductor does not come into its own until a closed loop, a so-called electric circuit, is formed. In such a loop the highly mobile electrons can constantly be moved around without producing any piling up of charge carriers with positive or negative polarity at different locations and as a consequence any back driving forces.

To maintain a constant flow of electrons, the same number of electrons which enter a certain volume element per unit time have to leave this element. Only under this condition no piling up of charge carriers will occur and a dynamic equilibrium or stationary state can be maintained.

1.1.5. Definition of electric current

A certain amount of charge q , which is flowing through a cross section of a conductor is equal to the number of electrons n , crossing this section, multiplied by the elementary charge. If this elementary charge is indicated as e we have: $q = ne$.

The amount of electric current at a certain cross section is determined by the charge and so by the number of electrons n , passing a specific cross section during a certain time period Δt . The electric current is indicated as I .

$$I = ne/\Delta t = q/\Delta t.$$

This unit of the electric current is called "amps", abbreviated A, in honour of the French physicist André-Marie Ampère (1775-1836). A current of 1 A corresponds to a flow of 1 Coulomb = $6,2 \cdot 10^{18}$ electrons per second through a cross section.

1.1.6. Ohm's law

If a constant current has to be driven through a resistor it needs a certain voltage or potential difference across the outlets of the resistor.

If the voltage is changed it is plausible to expect a corresponding change of the current. What is not evident is the question if this relation is linear, if the current changes proportional to the voltage.

Under normal conditions a proportional relation is rather seldom. If the current changes, normally the temperature of the resistor and therefore its resistance changes. This implies a non-linear relation between voltage and current. If, however, the temperature of the resistor and all other properties (length, cross section) remain constant, it has been experimentally proven that for metallic and for most solid state conductors there exists a strict proportional relation between voltage and current.

Conclusion: If a constant current I is driven by a voltage V through a resistor with resistance R and if all external parameters remain constant we have: $V/I = \text{constant}$. This relation was first detected by the physicist Ohm and is called Ohm's law.

By convention this constant, which is characteristic for the specific resistor, is used as definition for the resistance R .

$R = V/I$. The unit of resistance is Ohm, abbreviated as Ω , in honour of the German physicist Georg Simon Ohm (1789-1854).

1.1.7. Functioning of a power source

An electric power source consists in principle of a conductive device which is connected to the outside by two metallic contacts. In addition, an essential property has to exist. A power source can apply a force on the internal electrons to move them from one external contact towards the other. The kind of force is different for different kinds of power sources. Within a battery chemical forces are active, within a generator electromagnetic forces can be applied.

The action of these forces is always the same: At one of the external contacts an excess of electrons will occur. These electrons are missing at the other contact and will show up there as a positive charge.

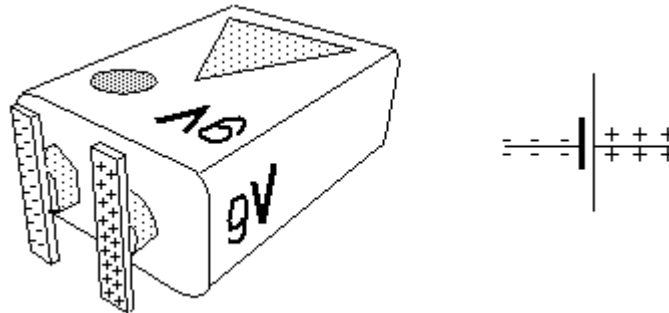

Fig. 1: Battery as power source
with surface charges at the metallic contacts

A basic law comes into play here: Additional electrons can never exist inside of a metallic conductor but only at its surface.

Why additional electrons do not leave such a surface but can be collected there is not easy to explain. Factors like the temperature of the conductor, the geometrical property of its surface and the electric property of the surrounding medium play an important role.

Any further explanation is not necessary for an understanding of the following. It is sufficient to accept as an experimentally proven fact that additional electrons can exist at the surface of a metallic conductor and only at its surface.

The larger the density of the additional positive or negative charges at the surface of the metallic contacts, the more these charge carriers repel each other. A certain limit will be reached, which is characteristic for the actual power source, where these repelling Coulomb forces will prevent any further accumulation of electrons. A state of equilibrium will be established between the internal force of the power source and the back driving Coulomb forces

1.2. Surface charges in electric circuits

1.2.1. Surface charges on conductors

Connecting the contacts of a power source with metallic conductors is in principle nothing different than increasing the surface of these contacts.

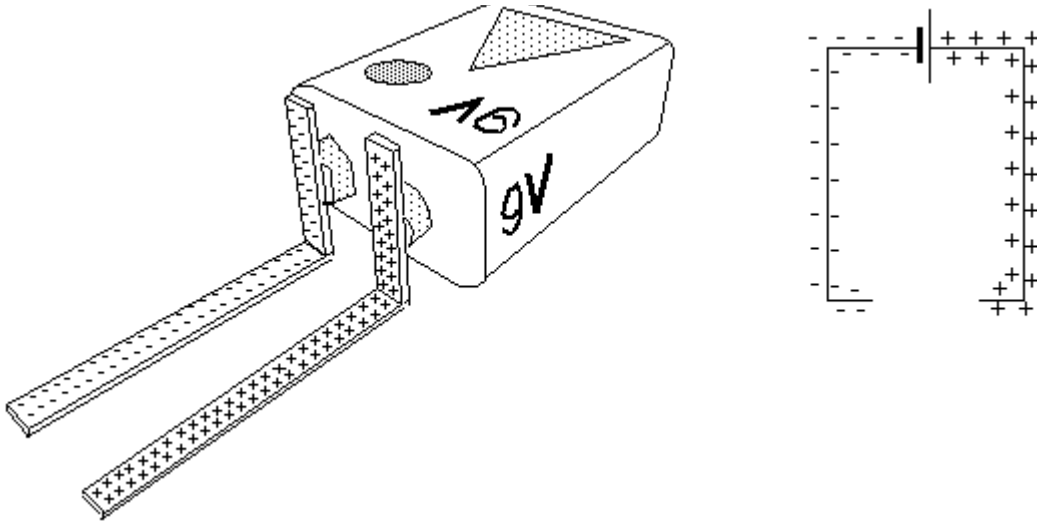

Fig. 2: Power source with connected conductors and surface charges

Caused by their mutual repulsion, these charge carriers will redistribute on this enlarged surface and therefore reduce their density. For a short moment this implies a non-equilibrium between the internal force of the power source and the Coulomb forces. Some additional electrons will be pushed on to these enlarged surfaces until the original density and an equilibrium between the involved forces is re-established.

1.2.2. Surface charges within a closed circuit

If the conductors are connected by a resistor and if the power source is strong enough to replace the electrons drifting through the resistor, a circular current will result, where all electrons inside of the conductors will take part.

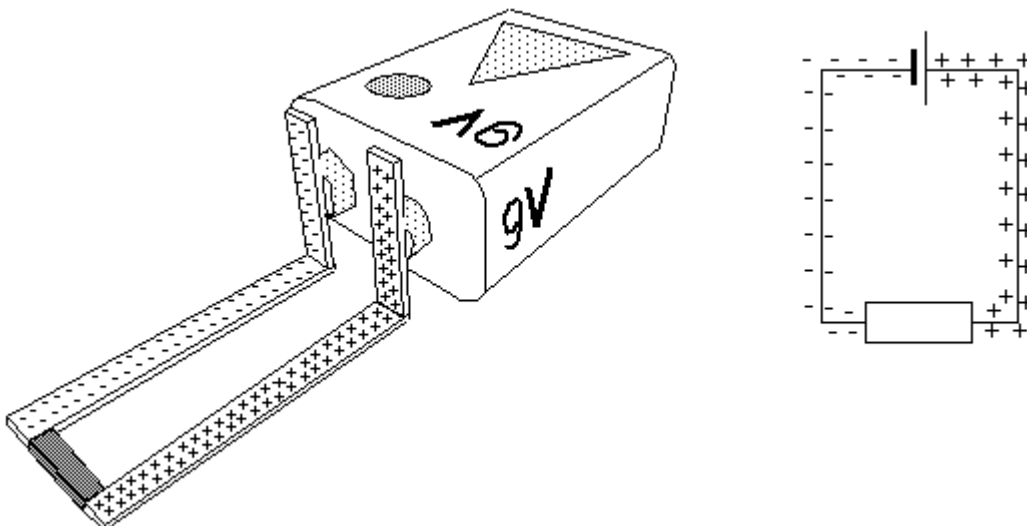

Fig. 3: A closed circuit and surface charges

As long as the driving force of the power source remains constant the charges on the surfaces of the conductors will remain, however, will start drifting along together with the bulk of internal charges.

1.2.3. Distribution of surface charges on current carrying conductors

All conductors possess a certain internal resistivity. To maintain an electric current through such a conductor it therefore needs an internal driving force to overcome the opposing effect of this resistivity.

Such an internal force, which has to be oriented in parallel to the axis of the conductor can only be produced by a certain distribution of charges on the surface of such conductors.

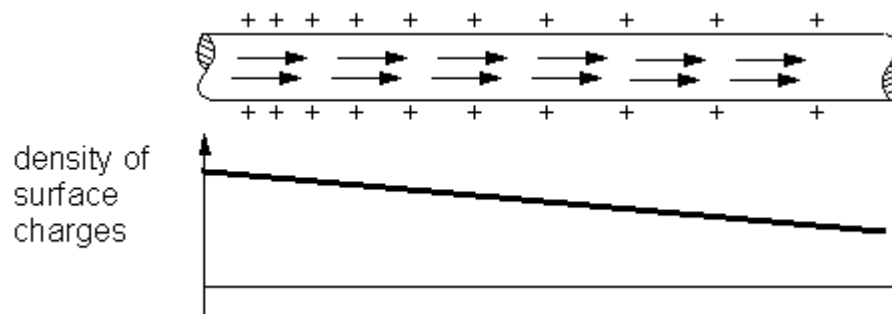

Fig. 4: Linear density distribution of surface charges on a rectilinear conductor

For the simplest case of a rectilinear homogeneous conductor, carrying a constant current, it can be calculated that it needs a linear change in the distribution of surface charges to produce an internal constant force oriented parallel to the conductor. This is also called a linear gradient of the surface charge distribution. The corresponding calculation is based on Coulomb's law and the longer and thinner the conductor the better is the fit between calculation and reality.

If a conductor is shorter or curvilinear the charge distribution on the surfaces needs to be more complex to produce an internal force which is oriented parallel to the axis of wire. The corresponding calculations are elaborate and complex. In general it can be stated that the density of electrons on the outbound surface of a conductor is larger than at the inner side and vice versa for positive surface charges.

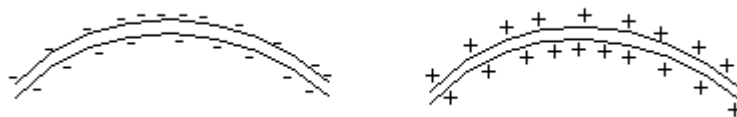

Fig. 5: Distribution of surface charges for curvilinear conductors (qualitatively)

Since the resistivity of metallic conductors is rather small the gradient of the surface charge density is rather small and can usually be neglected. For a qualitative understanding, however, the existence of surface charges and gradients in density distribution is indispensable.

1.2.4. Charges at the separating layers between resistors and conductors

If a conductor is electrically connected with a resistor a layer is formed separating the area with high conductivity from the resistive part with low conductivity.

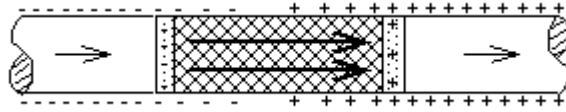

Fig. 6: Charged layers between conductors and resistors

Depending on the type of resistor these layers have a different thickness, where the conductivity of the material is changed either continuously or step wise and this over several orders of magnitude.

These layers at both ends of a resistor do not remain neutral when electrons are pushed through. Within the layer in front of the resistor (in respect to the flow of electrons) a few electron will pile up because ahead of them lies an area of low conductivity. This layer will carry a charge with negative polarity. From the layer behind the resistor some electrons will escape because an area with high conductive lies ahead of them. Some charged atom ions with positive polarity are left behind. This layer will carry a charge with positive polarity.

Differently distributed charges on the surfaces as well as the charged layers at both ends of the resistor will produce attracting and repelling forces to drive the electrons through the resistor

If the force of the battery will be increased, the gradient of the charge density and the charge within the separating layers will be increased. As a result the force on the mobile electrons will be increased, resulting in a larger current, i.e. a larger number of electrons passing a cross section per time period.

1.2.5. Voltage and surface charges

A voltage or potential difference between two points within an electric circuit is present whenever charges are separated, either in form of surfaces with a certain density of charges with opposite polarity or with a difference in surface charge density.

Such a separation of charges call some Coulomb forces into existence which try to re-install neutrality and these forces are the actual cause for voltage or potential difference. This is valid for electrostatic situations as well as for current carrying electric circuits.

Voltage or potential difference is indicated in English speaking countries as V , in German speaking countries as U .

1.3. Voltage and energy transfer

1.3.1. Quantitative determination of potential difference or voltage

In physics it is always necessary that a term like potential difference is not only described qualitatively. It also needs a method to be measured quantitatively.

For such a quantitative determination it is not possible to measure directly the surface charges or the accompanying Coulomb forces. The density of the additional electrons on the surface of current carrying conductors are in general rather small

and are depending on different geometrical factors. The same holds for the gradients of their density.

Independent of such external factors, however, is the work done by these forces or in other words the energy transformation which results from a certain current driven by a certain voltage or potential difference.

This offers the possibility to relate voltage or potential difference between two points A and B to the amount of energy which is transformed when a certain amount of charge is moved from A to B. In mathematical form: $U = E/q$.

Numerically voltage or potential difference is equal to the amount of energy which is transformed if a unit of 1 Coulomb is moved from A to B.

The unit of voltage or potential difference is 1 Volt, abbreviated as V, in honour of the Italian physicist Alessandro Graf von Volta (1745-1827).

1.3.2. Energy transformation in relation to voltage and current

Given an electric current of strength $I = q/t$ driven by an applied voltage $V = E/q$ between the points A and B.

If this current flows from A to B during a time period t , an amount of charge $q = I \cdot t$ will be transported from A to B¹.

For the energy transformation it follows:

$$E = \frac{E}{q} \cdot q = \frac{E}{q} \cdot \frac{q}{t} \cdot t = U \cdot I \cdot t$$

1.3.3. Extended definition of voltage between points in space

The definition of voltage as E/q makes it possible to define a voltage not only when charges are separated but also between two points A and B in an empty space between separated charges, where A and B themselves do not carry any charges.

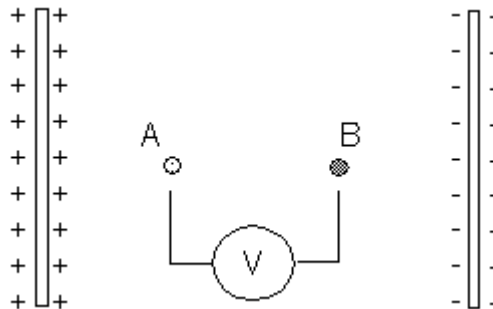

Fig. 7: Potential difference between 2 neutral points

As shown in the figure above there will be a difference between A and B in respect to the distance to the external charges and therefore energy will be transformed if a charge is moved from A to B.

1. If this statement is not immediately evident, a comparison from mechanics may be helpful. To lift a certain quantity of water m_0 by a certain distance d , two different methods can be applied.
 1. The amount of water m_0 can be lifted all together in a container by the distance d .
 2. A water current $I = m/t$ flows in a vertical pipe of length d upwards for a certain period of time so that we have $m_0 = I \cdot t$.

Based on the definition $V = E/q$ we can define a voltage between A and B, even though there are no separated charges at A and B.

The two locations A and B differ in this case not because of different density in surface charges but because of different distances within a system of separated charges.

1.4. Models for the electric circuit

1.4.1. Comparison between a stiff ring and a circuit

To illustrate the processes within an electric circuit it is helpful to compare such a circuit with a stiff ring driven by a motor at one place and restricted in its motion by a brake at another place.

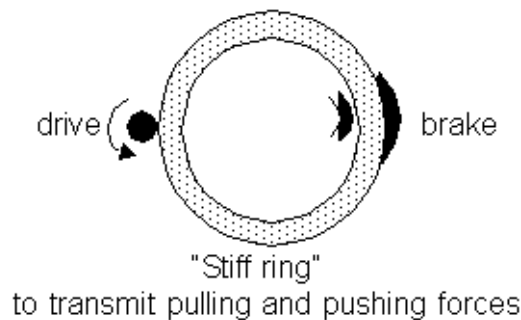

Fig. 8: Mechanical model for the electric circuit

The characterisation „stiff“ should not be understood in an absolute sense. Every real object shows some elastic behaviour under the impact of a force. It may be rather small, however, it will never be zero.

1.4.2. Difference between feed and return line

Real objects are, as already mentioned, never stiff in an absolute sense, but will always show some elastic behaviour. This applies to liquids like water as well as for solids like for instance steel or rubber. Only the degree of elasticity is different.

If this elastic behaviour is taken into account for a stiff ring, which is used as device to transmit a force, it can be concluded that the two parts, the part before the brake under push and the part behind the brake under pull will deform differently.

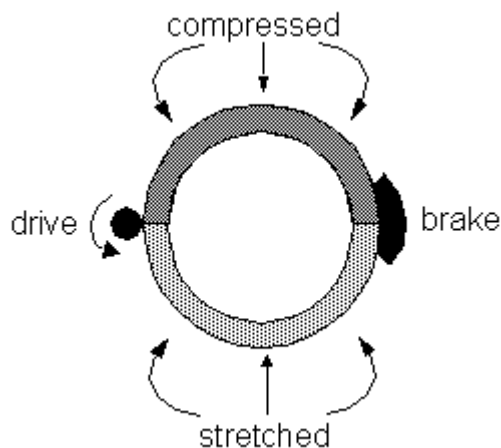

Fig. 9: Elastic deformation of a stiff ring

The pushed part will become slightly compressed, the pulled part will become slightly stretched. This difference in deformation will be sustained by the motor and will produce the necessary force at the brake to keep the ring moving.

While passing the brake the material of the ring will expand from a compressed to a stretched state. This change in density is certainly rather small in comparison with the amount of circulating material, however, it always exists. To know about these deformation, however, will be helpful if not necessary to reach a deeper understanding of the process to transmit a force, especially in comparison with the functioning of an electric circuit.

1.4.3. Comparison between model and electric circuit

The similarities between the electric circuit and a stiff ring with a drive and a brake can be summarized as follows:

Stiff ring	Electric circuit
The stiff ring serves to transmit a force	The electric circuit transmits a force
Matter moves in a circle	Electrons move in a circle.
Matter is not consumed	Electrons (electric current) are not consumed.
The stiff ring is pushed by the motor on one side and pulled on the other side.	The mobile or free electrons within a conductor can also be seen as an ensemble like a gas, a so-called "electron gas". This "electron gas" is pushed at one side by the force of the power source and pushed by the other side.
The stiff ring will be compressed or stretched by the motor i.e. its density will be changed.	The "electron gas" will be compressed and stretched respectively. As a result the density of the charges at the surface of the conductors and just before and behind a resistor will be changed.
When passing through a braking area the driving force of the motor is transformed to a density change of the stiff ring, which on its part can be looked at as the local cause to overcome the braking action.	When an electric current is flowing through a resistor, the force of the power source is transformed to a difference in charge density before and behind the resistor. This change in charge density can be looked at as a local force which is necessary to keep the current flowing through the resistor.

The main structural difference between the stiff ring and the electric current is the fact that the density of matter when being pushed or pulled will change over the complete cross section.

For an electric current only the density of charges on the surface of metallic conductors can change. The internal parts of conductors are always neutral.

In addition there is an obvious difference in respect to practicability. The stiff ring is rather inflexible with no application in technical areas. There are more flexible

variants in form of a bicycle chain or a drive belt with wide spread use. These variants as model for the electric current, however, are of limited use, because the driving force in these systems can only apply a pull and no push. The analogy to the symmetry of the Coulomb force with attraction and repulsion is missing

1.4.4. Restricted models for the electric current

In comparison with the stiff ring, the bicycle chain or the drive belt other circular systems like a hot-water system, a conveyor belt or a blood circuit can be used as model for the electric circuit in a much more restricted manner.

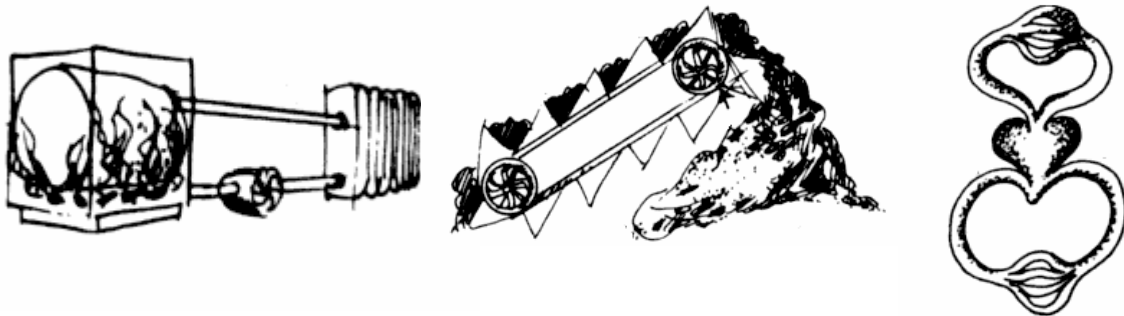

Fig. 10: Circular systems, where energy-rich matter is transported
- only of restricted use as model for the electric current

These systems do not transmit a force but mainly energy-rich matter. The transmission of energy is therefore coupled to the motion of the transmitting medium. Within an electric circuit, however, the electrons are drifting with a rather low velocity while the energy is spread out with nearly the speed of light.

1.4.5. Problematic models for the electric circuit

In some textbooks systems are shown as model for the electric circuit, where the single components can be driven individually. Trucks on a highway running back and forth between a loading and unloading station are such an example.



Fig. 11: Trucks running back and forth on a highway
a problematic model for an electric circuit

In contrast to such a system electrons do not have an own drive but are driven by an external power source. No electron can for instance stop or slow down if it encounters a resistor without influencing all other electrons in the same way.

However, if a traffic jam occurs on a highway, only the cars in front of this jam are affected. The cars behind the jam and those on the opposite lane continue to move unaffected.

The following example from an American textbook demonstrates that such reflections are not self-evident.

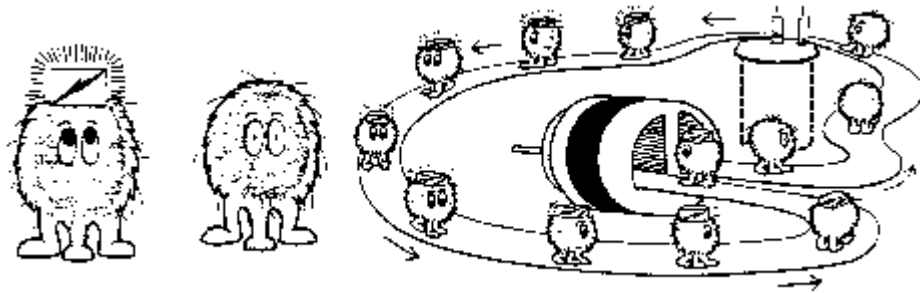

Fig. 12: Problematic model for the electric circuit

In this model it is again assumed that the electrons can move ahead by themselves while transporting energy from the battery to the motor.

Many questions remain open.

- Why will all electrons stop if a single electron will be stopped?
- What happens if a second motor is added behind the first one?
- Why can the effect of the battery spread out with higher speed than the speed of the electrons?

This model disregards that the interconnection between the mobile electrons is an essential property of the electric circuit, without which it would lose most of its unique properties as a system.

1.5. Capacitor behaviour of electric circuits

1.5.1. Properties of a capacitor

In principle a capacitor consists of two relatively large metallic foils - or isolating plates with metallic surfaces - separated by a rather thin layer. This separating layer is often filled with some isolating material to prevent any electric conduct between the two internal metallic surfaces.

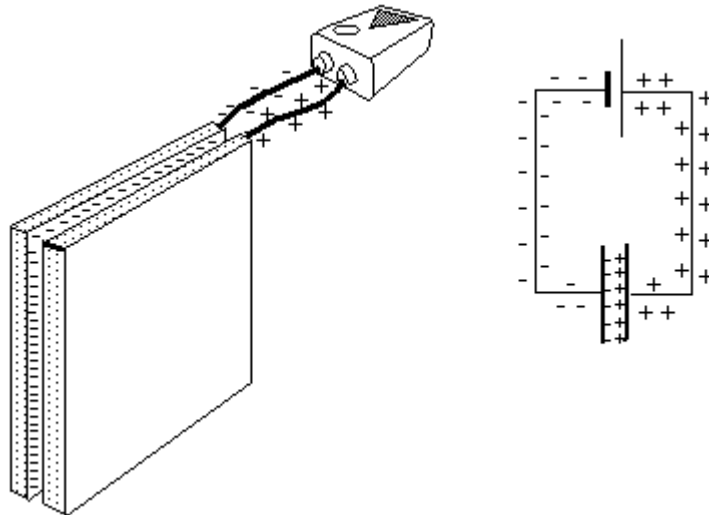

Fig. 13: Basic construction of a capacitor, connected to a power source
Significantly increased charge density between the plates
compared to the density on the wires

If a power source is connected with a capacitor by two conductive wires, electrons are moved towards one of the two internal surfaces due to the driving force of the source. On the opposite surface the same number of atoms will no longer be neutral and show up as positive charge.

Because the separating layer between the two metallic surfaces is rather thin the attracting Coulomb forces between these opposite charges are increased and start to play an important role. These forces reduce the mutually repelling forces on each internal surface of the capacitor, and this implies that the driving force of the power source can create a much higher density of surface charges on these internal surfaces until again an equilibrium is reached between the driving force of the power source and the repelling forces of the compressed surface charges.

The thinner the separating layer the larger is the attracting Coulomb force across this layer. This implies an increased reduction of the mutually repelling Coulomb forces on each surface and an enlarged density of surface charges as a result of an applied voltage.

The number of additional charges on the surface of a normal conductor is rather small because the repelling forces between such charges are rather large so that it needs a small density of surface charge to reach an equilibrium with the driving force of a power source.

The electrons on the surface of normal conductors show - alltagssprachlich ausgedrückt - hardly any elastic behavior, they can hardly be compressed.

The charges on the internal surfaces of a capacitor, however, attract each other and are therefore much more elastic and compressible compared to a normal conductor.

1.5.2. Capacitor and capacitance

The amount of charge q which can be compressed into a capacitor until an equilibrium is reached is proportional to the applied voltage V .

In other words: Q/U is a characteristic constant for each capacitor. It is called capacitance and is indicated as C . $C = Q/U$.

The unit of capacitance is 1 Farad, abbreviated 1 F, in honour of the English physicist Michael Faraday (1791-1867).

A capacitance of 1 F indicates, that for an applied voltage of 1 V a unit charge of $1 \text{ Q} = 6,2 \cdot 10^{18}$ electrons will flow into a capacitor. This is a large number for a small voltage and can normally not be realized. The capacitance of normally available capacitors lay in the range of μF to nF (10^{-6} to 10^{-9}F).

1.5.3. Charging and de-charging of capacitors

It seems obvious to assume that the charging of a capacitor will take some time until a stationary state is reached. A large number of electrons have to be brought to the inner surface of the capacitor until the resulting density is high enough to block any further input of electrons.

It seems further reasonable to assume that the time period T for reaching this stationary state will depend on the seize of the capacitance C and the resistance R of the conducting wires. The larger C and R the larger T .

The seize of the charging current is not constant. It is decreasing in time because of the increasing amount of Coulomb forces which are opposing the driving force of the power source.

As proven by theory and experiment the time dependence of the charging current follows an exponential function with negative exponent.



Abb. 14: Time dependence of a capacitor charging current

1.5.4. Simple electric circuits with and without circuit capacitance

Usually the most simple electric circuit is seen as a system where a power source and a resistor are connected by two conducting wires.

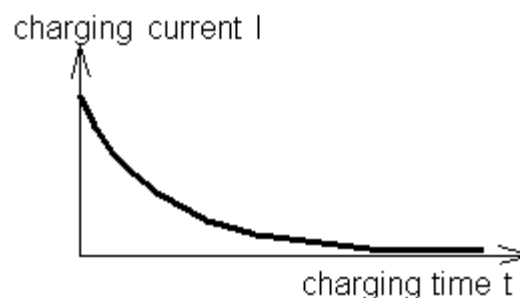

Fig. 15: Circuit diagram of a simple electric circuit

This is an idealization because it is neglected that the surfaces of the wires form some kind of capacitor with a small but always non-zero capacitance.

As long as the focus is set only on stationary states without asking for a causal relation between such states, this kind of representation is sufficient.

However, for a more detailed consideration it is necessary to include the capacitance of the wires.

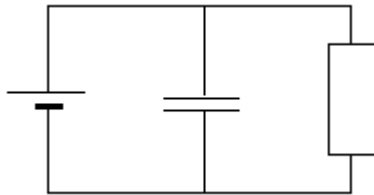

Fig. 16: Equivalent circuit diagram of a simple electric circuit, including the capacitance of the conducting wires

As a consequence and depending on the size of this capacitance the transition of one to the next stationary state will be more or less retarded

In the following a simulation program will be used where the capacitance of the wires is strongly increased so that the transition processes become visible.

The main reason for this is a didactical one. The fact should be made very clear that nature does not jump from one state to another but that there exists always a causal relation between two stationary states in form of specific transition processes.

The second reason is a technical one. A rather simple algorithm can be used to calculate such retardation until the final stationary state is reached.

2. Simulation of current and voltage in circuits

2.1. Display of current and voltage in simple electric circuits

The simulation program used here shows on the left a circuit as usual in 2d, where the current is visualised graphically at selected locations in form triangles.

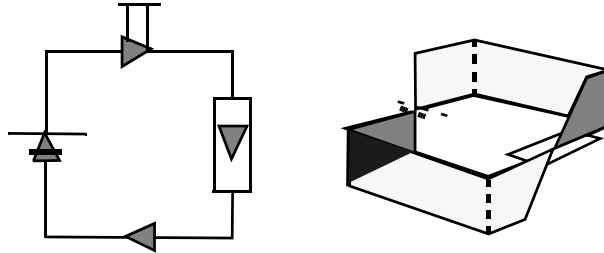

Fig. 17: Simulation of current and voltage as interactive applet

The window on the right shows the circuit in 3d and indicates the voltage along the components perpendicular to the circuit.

In a first approximation this graphical display of voltage perpendicular to the circuit can be related to the density of surface charges.

The position of the switched in the left window can be changed. Further more the numerical values for V , R and I can be displayed.

The position of the complete circuit in the right window can be rotated to optimize the visibility of the distribution of voltage along the circuit.

The display of the enlarged transient process can at least partially be suppressed by setting a certain number of calculation steps N before the simulation is shown.

Together with the simulation program an editor is offered to construct various circuits, which can be saved as interactive applets.

Some examples

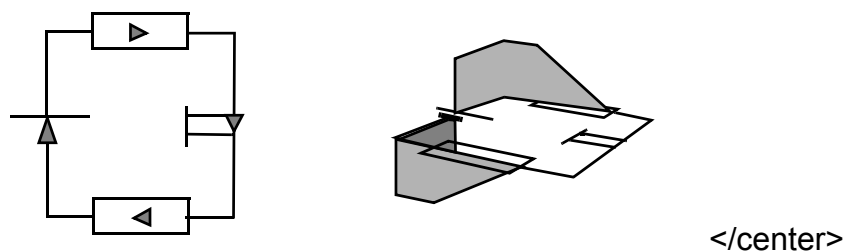

Fig. 18: Series circuit with 2 resistors

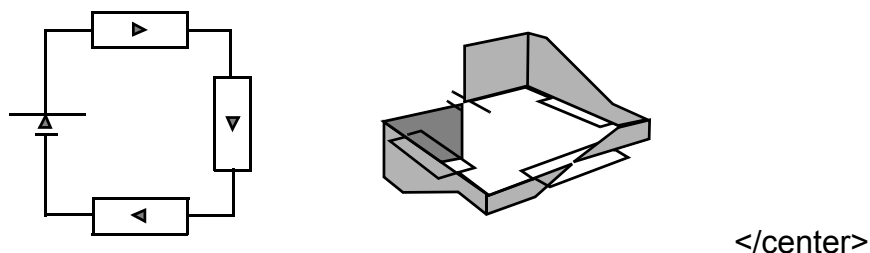
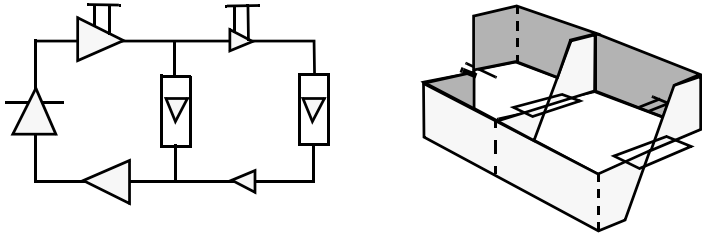
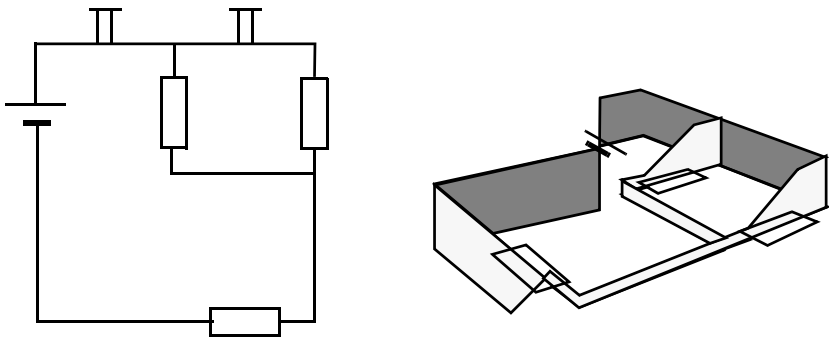

Fig. 19: Series circuit with 3 resistors



</center>

Fig. 20: Circuit with 2 resistors in parallel



</center>

Fig. 21: Mixed circuit

2.2. Stationary states and transient processes on a double line

If a power source is connected to a circuit, the surface charges will spread out with nearly the speed of light over the entire available surface.

For circuits of usual size a new stationary state will already be reached after a time period at the order of 10^{-7} seconds.

To study this transient process in more detail the simulation program "TL-transmission line" can be used. This program simulates the propagation of voltage and current along a double line on the basis of Maxwell's equations.

A double line is characterized by the fact that distance and diameter of the wires are negligible compared to the length of the wires. Ideally the wires should be straight or show only a slight bending.

The following simulation shows the simple transient process when a dc-power source is connected to a double line, terminated by a resistor.

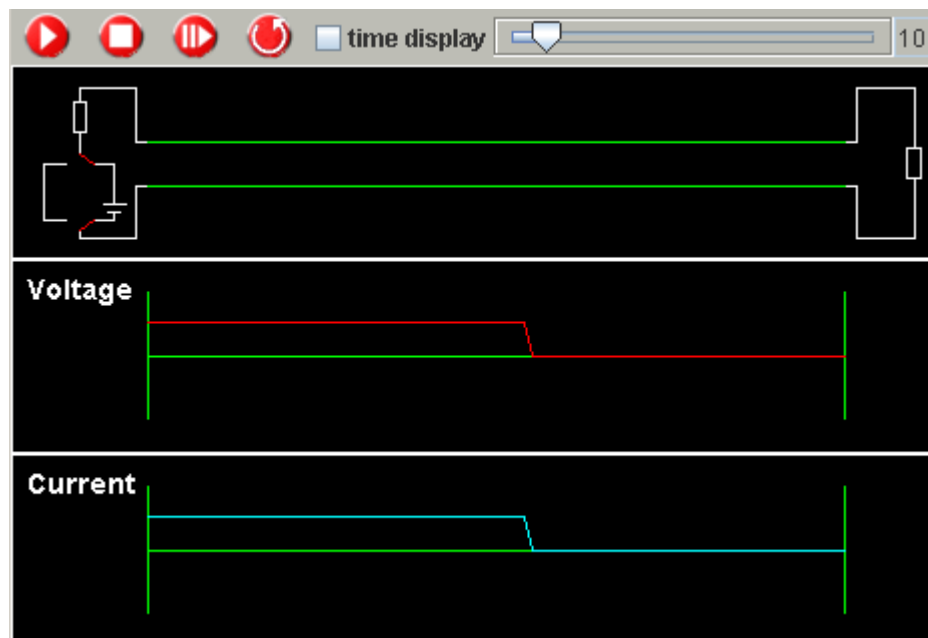

Fig. 22: Simulation of a transient process after a power source is connected to a double line

